

NET-PAD

Clarity Hardware

ENG

Code/Rev.: M052/80I

Date: 2026-05-22

Phone: +420 251 013 400

clarity@dataapex.com

www.dataapex.com

DataApex Ltd.
Petrzilkova 2583/13
158 00 Prague 5
Czech Republic

Clarity[®], DataApex[®] and ▲[®] are trademarks of DataApex Ltd. Microsoft[®] and Windows[™] are trademarks of Microsoft Corporation.
DataApex reserves the right to make changes to manuals without prior notice. Updated manuals can be downloaded from www.dataapex.com.

Author: zte

Contents

1 Net-PAD description	1
1.1 Back view	2
1.2 Left view	3
1.3 Right view	3
2 Requirements	5
3 Installation procedure	6
3.1 Hardware installations	6
3.1.1 Switch or HUB – connecting to LAN	6
3.1.2 PC – connecting directly to a computer	6
3.2 Network configurations	7
3.2.1 Single PC	7
3.2.2 LAN – fixed IP Addresses	7
3.2.3 LAN - DHCP server	8
3.2.4 LAN – ROUTER	8
3.3 Standard cable for Clarity station	9
3.4 Connection with Chromatograph	10
3.4.1 Connection of signal cables	10
3.4.2 Connection of starting cables	11
3.5 Clarity Configuration	12
3.5.1 Measuring on multiple instruments	16
3.5.2 Using multiple Net-PAD converters	17
4 Using the Net-PAD	18
4.1 DataApex Net-PAD Setup	18
4.1.1 DataApex Net-PAD Select	20
4.2 Method Setup	23
4.2.1 Method Setup - Measurement	23
4.2.2 Method Setup - Acquisition	24
4.3 Digital inputs and outputs	26
4.4 Device Monitor	27
5 Troubleshooting	28
5.1 Locate your problem	28
5.2 Problems with Net-PAD	29
5.3 Data Acquisition - non-functional	30
5.4 Data Acquisition - Simulated	32
6 Tables and specifications	33
6.1 Description of the INT7 connector (Male)	34

6.2 Parameters of digital inputs and outputs	35
6.3 Disposal and Recycling	36

To facilitate the orientation in the **Net-PAD** manual and **Clarity** chromatography station, different fonts are used throughout the manual. Meanings of these fonts are:

Open File (italics) describes the commands and names of fields in **Clarity**, parameters that can be entered into them or a window or dialog name.

WORK1 (capitals) indicates the name of the file and/or directory.

ACTIVE (capital italics) marks the state of the station or its part.

Chromatogram (blue underlined) marks clickable links referring to related chapters.

The bold text is sometimes also used for important parts of the text and the name of the **Clarity** station. Moreover, some sections are written in format other than normal text. These sections are formatted as follows:

Note: Notifies the reader of relevant information.

Caution: Warns the user of possibly dangerous or very important information.

Marks the problem statement or trouble question.

Description: Presents more detailed information on the problem, describes its causes, etc.

Solution: Marks the response to the question, presents a procedure how to remove it.

1 Net-PAD description

This manual describes the use of the **Net-PAD** with the **Clarity** software ver. **2.7 and later**.

Net-PAD is an external, Ethernet high resolution **A/D converter**. Data can be acquired from remote chromatograph over **LAN** (local **TCP/IP** network).

Two high-resolution A/D converter **channels** enable you to measure two independent signals from detectors.

Two **Onboard COM Ports** also provide direct control of selected instruments over a serial line.

Eight **digital outputs** (four of them are relays) and four **inputs** are used for synchronization and control of additional equipment.

Net-PAD is compatible with any GC, HPLC, GPC, IC, CE system with standard analog output. The **Clarity** Chromatography Station can handle any combination of available **DataApex** converters (internal PCI, external USB and TCP/IP).



Fig. 1: Net-PAD

1.1 Back view

The backside of the device lists all the important information necessary when configuring the **Net-PAD**.

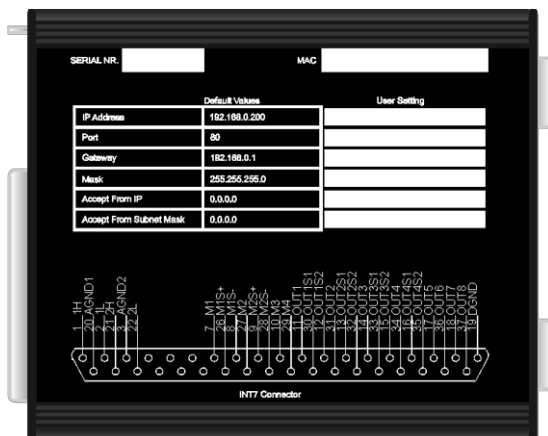

Fig. 2: The back side of the Net-PAD

Serial Nr.

Serial Number of the **Net-PAD** device. Use this number when communicating with **DataApex**.

MAC

MAC address is a unique network device address on the Ethernet and it is always factory preset. Using this address, the devices can be distinguished in the UDP mode of the configuration program.

Table

The **Default Values** lists the values preset by **DataApex**.

Note: Use a felt-tipped pen (the same that is used to write on CDs) to fill in your own settings.

For details on the individual parameters and their setting, see the chapter "**DataApex Net-PAD Setup**" on pg. 18.

INT7 connector

The **Net-PAD** uses an INT7-compatible connector. The scheme contains a brief description of the connector pins for quick reference.

See the chapter "**Standard cable for Clarity station**" on pg. 9. for description of the INT7 connector and the chapter "**Connection with Chromatograph**" on pg. 10. for description of wiring.

1.2 Left view

The left side provides the LAN connector, serial ports and LEDs indicating the state of the device.

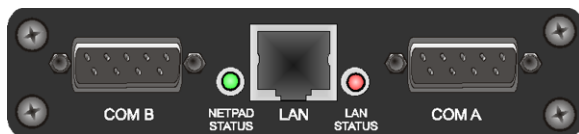

Fig. 3: The left side of the Net-PAD

COM A (B)

The COM ports serve for direct control of chromatography devices over a serial line (for more details see the chapter **Clarity Configuration** on pg. 12).

NetPAD Status

When the **Net-PAD** is powered on the green, LED can be in two states:

- **Blinking** = **Net-PAD** is idle, there is no analysis on any of the two channels.
- **Steady light** = **Net-PAD** acquires data at least on one of the two channels.

LAN

The LAN connector **TP45** (twisted pair).

Lan Status

When the **Net-PAD** is powered, the red LED can be in two states:

- **Blinking** = **Net-PAD** is connected to the LAN – blinking indicates data traffic on the LAN.
- **Steady light** = **Net-PAD** is connected to the LAN.

1.3 Right view

The right side provides **INT7** standard connector and power supply connector.

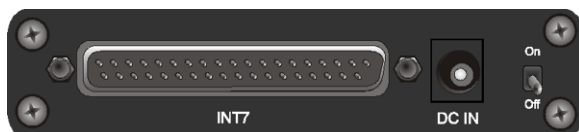

Fig. 4: The right side of the Net-PAD

INT7

The **INT7** connector serves for connecting the **Net-PAD** to the detectors. It also contains pins for digital outputs and digital inputs used for synchronization of start or for basic control of chromatography equipment from the **Clarity Event Table**.

- See the **Getting Started** manual, chapter *Device Setup and Wiring* for description of **INT7** cables and wiring.
- See the **Reference Guide** chapters:

- *Right Section of the dialog* – setting of the digital input for synchronization with chromatograph in the *System Configuration* dialog.
- *Digital Outputs* – for manual monitoring and control of the digital outputs.
- *Acquisition* – for **External Start/Stop** setting and *Event Table* in the *Method Setup - Acquisition* dialog.

DC IN

Connector of the DC power supply.

2 Requirements

- Local network using the **TCP/IP** protocol or a computer equipped with LAN card.
- Possibility to reserve an **IP Address**.
- **Clarity** Installation media.
- **LAN cable**:
 - **normal** - when connecting to a HUB or Switch
 - **crossed** - when connecting directly to a computer
- The **Net-PAD** external **A/D Converter** can be used with the **Clarity** software under following operating systems: **Windows 11/10/8.1/7^{SP1}** (From **Clarity 3.0** including the **64-bit OS versions**).
- **Net-PAD** is in Windows **2000** supported until **Clarity** version **3.0**, in Windows **XP^{SP3}** until **Clarity 7.4.1** and in **Windows Vista^{SP2}** until **Clarity 7.2**.
- The **Net-PAD** can also be used with **Clarity EA** stations.

3 Installation procedure

Ensure that you have *Administrator* access rights in your **Windows** OS before you proceed with the installation.

3.1 Hardware installations

3.1.1 Switch or HUB – connecting to LAN

When using a **DHCP** server, you have to reserve an **IP Address**. **Net-PAD** cannot obtain IP dynamically from DHCP.

Caution: Make sure that you use the straight LAN cable.

- Connect **Net-PAD** to the **Switch** or **HUB**.
- Connect the **Net-PAD** to the power supply.

For more details, see the chapter "**Network configurations**" on pg. 7.

3.1.2 PC – connecting directly to a computer

When connecting directly to a computer using its LAN connector, make sure the dynamic assigning of the IP addresses is off (Get IP address from DHCP).

Caution: Make sure that you use the crossed LAN cable.

- Connect the **Net-PAD** to the PC using its LAN connector.
- Connect the **Net-PAD** to the power supply.

For more details, see the chapter "**Network configurations**" on pg. 7.

Note: When using Net-Pad on Windows 10/11 there might be problem with detection of the available devices on network using the *Select and Setup Device* button. For possible workaround please see the chapter "Problems with Net-PAD"

3.2 Network configurations

3.2.1 Single PC

A single PC equipped with LAN card can be used together with **Net-PAD**. When using a **switch** or a **hub**, multiple **Net-PADs** can be connected to one PC.

Settings

PC: LAN card, TCP/IP protocol.

Both PC and **Net-PAD** should be configured on the same IP range.

Caution: Crossed LAN cable is required (in case the **Net-PAD** is connected to LAN card directly, without using the **switch**).

Tab. 1: Recommended IP settings:

	Net-PAD	LAN card
IP	192.168.0.200	192.168.0.1
Port	80	---
Subnet Mask	255.255.255.0	255.255.255.0
Default Gateway	192.168.0.1	192.168.0.1
Accept From IP	0.0.0.0	---
Accept From Subnet Mask	0.0.0.0	---

Firewall

Ensure that the firewall does not block communication from the **Net-PAD**.

Internet connection

Be aware that many Internet connections are provided using the LAN card. If this is the case a separate LAN card must be configured for each Internet and **Net-PAD**.

3.2.2 LAN – fixed IP Addresses

- In dialog described in the **Fig. 14** on pg. **18**, use the *Select or Setup Device* button.
- **Clarity** will automatically find the **Net-PAD** (using the UDP protocol).
- In dialog described in the **Fig. 18** on pg. **21**, assign the **Net-PAD** a unique IP Address from your local network IP Address range.

3.2.3 LAN - DHCP server

Net-PAD **does not support** dynamic allocation of IP Address provided by **DHCP** server.

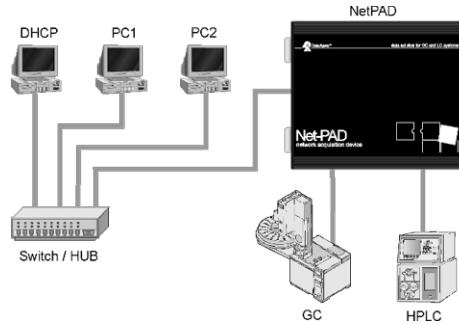

Fig. 5: Net-PAD in LAN with DHCP server

It is necessary to reserve the Address used by **Net-PAD** in the **DHCP** server, so that it does not attempt to assign it to another device.

3.2.4 LAN – ROUTER

Caution: When using **Net-PAD** connected to a router, the driver cannot perform the automatic **Net-PAD** search using UDP protocol.

- Select appropriate **IP Address : Port** in the *DataApex Net-PAD Setup* dialog manually (for more details see the chapter **DataApex Net-PAD Setup** on pg. 18).
- Then it will be possible to use the *Select or Setup Device* button to open the *DataApex Net-PAD Setup* dialog and edit the **Net-PAD settings** (for more details see the chapter **DataApex Net-PAD Select** on pg. 20).

3.3 Standard cable for Clarity station

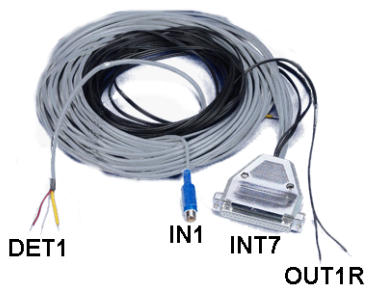

Fig. 6: Cables for the Clarity station package

The standard **Clarity** station package includes a cable composed of signal and starting cables for connecting the **Clarity** station to the chromatograph.

Signal cables

Labeled **DET1** and **DET2**, the cables are supplied as standard without connectors [bare stripped and tinned endings – red (+), white (-) and shielding (analogue ground)].

Starting (marker) cables

Labeled **IN1** and **IN2**, ended with CINCH connector (female). The following cables can be connected to this CINCH connector:

- A cable terminated with free leads [red (+), shielding (digital ground)] for direct connection to the chromatograph.
- A cable terminated with a button for cases where a starting contact is not available and it is necessary to perform a manual start.

Both types of cables are supplied for each starting cable.

Digital output cables

Relay contacts labeled **OUT1R** and **OUT2R**, terminated with free leads. These are used for synchronizing autosamplers without an **AS Control** module in the **ACTIVE** Sequence or for controlling other devices.

At the converter end the cable is always terminated with a DB-37F connector (37-pin female connector).

3.4 Connection with Chromatograph

Connect the cables according to one of the following diagrams in the **Fig. 7** on pg. **10**. Use the symmetrical connection only when you are sure that the chromatograph/detector is equipped with a symmetrical output – it is necessary to read through the instructions for the corresponding chromatograph.

Net-PAD use the standard **INT7** Connector.

Note: A description of the INT7 connector can be found in the chapter "**Description of the INT7 connector (Male)**" on pg. **34**.

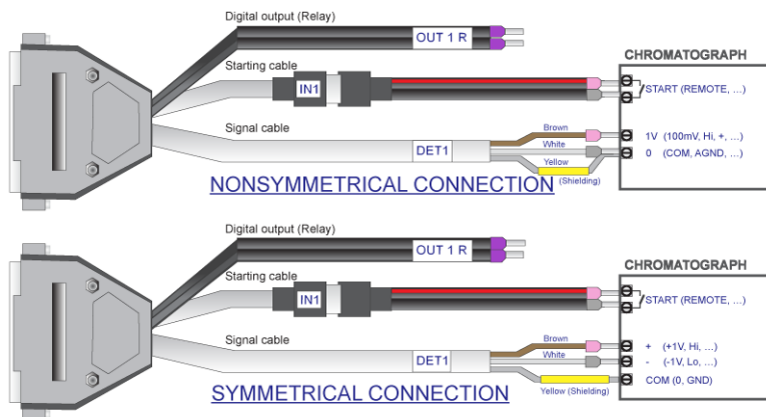

Fig. 7: Connecting Clarity to chromatograph

3.4.1 Connection of signal cables

Signal inputs of the A/D converters are symmetrical: + (red), - (white) and analogue ground (copper braiding).

Caution: Shielding must be connected. It serves not only as the shielding but also as the analogue earth against which the measurement takes place. In the case of asymmetrical output of a detector (only two connectors) shielding must be connected to the white lead! No lead of the signal cable may remain unconnected.

Try to connect to the detector output of the chromatograph with the largest possible signal level, usually indicated in the chromatograph as **INTEGRATOR** (signal approx. 1 V). The level of the signal on the output marked **RECORDER** is usually only approx. 10 mV. For easier alterations of the wiring, we supply a **SV9 Terminal board** with screw contacts for **Net-PAD** A/D converter.

Note: This **SV9 Terminal Board** is not suitable for applications with small signals or with high electromagnetic interference. This is because the **SV9 Terminal Board** uses leads and screw contacts that are not shielded.

3.4.2 Connection of starting cables

Starting input reacts to a change of the TTL level (5 V / 0 V) or to a connection by any contact (button, contact of relay).

The input implicitly reacts to a change from *HIGH* to *LOW* (contact closure). The input function may be altered by changing the *Down* option to *Up* in the *External Start/Stop* section of the *Method Setup - Measurement* dialog (accessible from the *Instrument* window using the *Method - Measurement* command).

For schemes and hints describing the typical autosampler wiring, please see the **Connecting Autosamplers** chapter of the **Getting Started Manual**.

3.5 Clarity Configuration

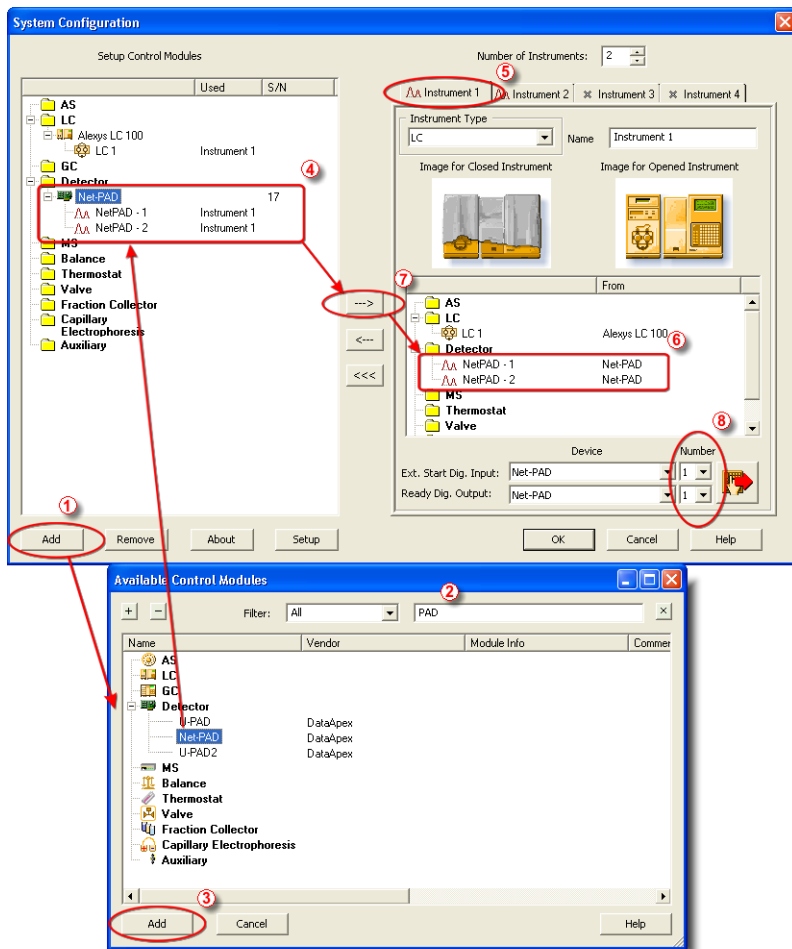

Fig. 8: System Configuration

Caution: Before installing the **Net-PAD**, install the control module you are about to use with the **Net-PAD**. Otherwise, no new COM ports will be available for installed control module.

- Invoke the *System Configuration* dialog accessible from the *Clarity* window using the *System – Configuration...* command.
- Press the *Add* button ① (See Fig. 8 on pg. 12.) to invoke the *Available Control*

Modules dialog.

- You can specify the searching filter ② to simplify the finding of the driver.
- Select the **Net-PAD** and press the **Add** ③ button.
- The [DataApex Net-PAD Setup](#) dialog will appear

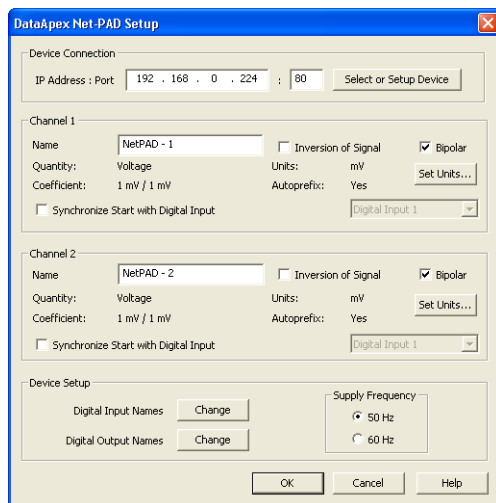

Fig. 9: DataApex Net-PAD Setup

- First click on the *Select or Setup Device* button.
- [DataApex Net-PAD Select \(and Network Setup\)](#) dialog will appear.

Net-PAD will automatically search your local network and produce a list of all identified **Net-PADs**.

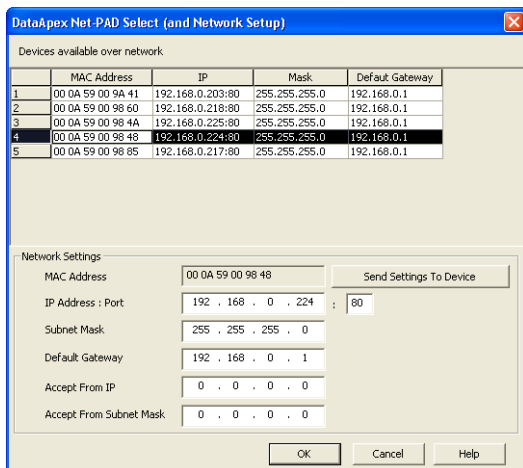

Fig. 10: DataApex Net-PAD Select (and Network Setup dialog)

- Select the appropriate **Net-PAD** from the **Devices available over network** table. And if necessary set its properties in the **Network Settings** (for more details see the chapter **Network configurations** on pg. 7).

Note: If you have multiple **Net-PAD** devices, check the listed **MAC Address** against the one printed on the backside of the **Net-PAD**.

- Press **OK** to get back to the *DataApex Net-PAD Setup* dialog and set the **Device Parameters** (detector names and parameters of the A/D channels).
- Press the **OK** button.
- The **Net-PAD** will appear in the *Setup Control Modules* list ④ of the *System Configuration* dialog.
- Drag and drop the **Net-PAD** icon from the *Setup Control Modules* list ④ on the left side of the *System Configuration* dialog to the desired *Instrument* ⑤ tab on the right side ⑥ (or use the <--> button ⑦ to do so).
- Set the *Ext. Start Dig. Input* and *Ready Dig. Output* numbers ⑧ for your acquisition card according to the wires being used for synchronization.

Two new **COM A** and **COM B** ports are now available in **Clarity**. These ports are used for control of connected chromatography devices over a serial line using the **Clarity Control Modules**.

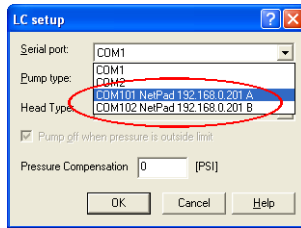

Fig. 11: New COM ports in LC Setup

Each **Net-PAD** will add two new COM ports numbered 101, 102 ... 10x, depending on the number of connected **Net-PADs**.

Caution: These **COM Ports** will be available only within **Clarity**. They will not be listed in the *Windows Device Manager*.

When using the **Net-PADs COM ports** for direct control of attached devices by **Clarity Control Modules** be aware that the data throughput can be limited by the capabilities of the local network.

Note: The configuration dialog of the **Net-PAD** ([DataApex Net-PAD Setup](#)) can be displayed any time by double-clicking on its icon or using the *Setup* button.

3.5.1 Measuring on multiple instruments

When measuring on multiple instruments using only a single **Net-PAD** to gather data, rather than dragging the entire **Net-PAD** icon from the *Setup Control Modules list* ①, drag the individual detector signals (**FID**, **UV-VIS** in this case) to separate *Instruments* ②, see **Fig. 12** on pg. 16. The *Instrument* to which the particular signal is connected is listed to the right ③ of the detector name in the *Setup Control Modules* section.

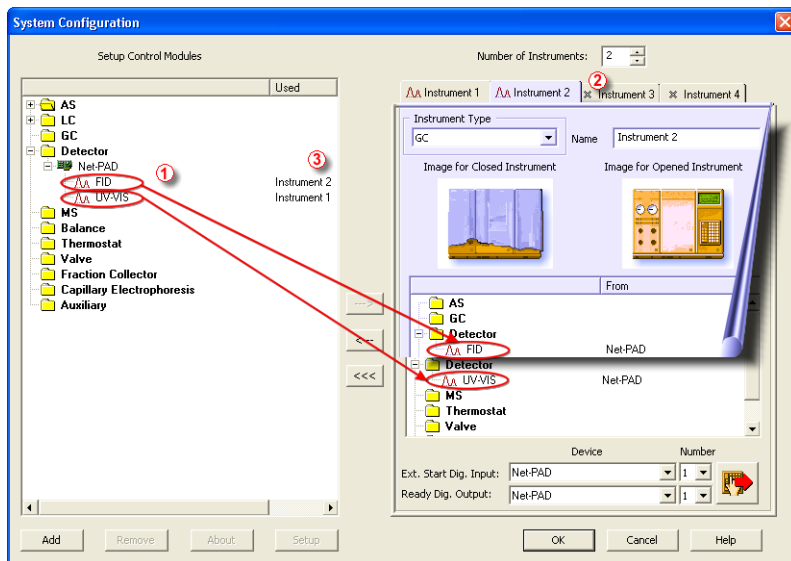

Fig. 12: System Configuration – multiple instruments

Note: Each independent **Clarity** instrument must have separate *Ext. Start Dig. Input* and *Ready Dig. Output* pins configured according to the actual wiring.

Note: A larger number of Instruments can be set than the amount you have purchased. You will not be able to measure on the surplus Instruments (indicated by a blue symbol of the curve on the tab), but you may use them e.g. for “offline” preparation of methods.

4 Using the Net-PAD

There are generally two places for setting the parameters of **Net-PAD** in **Clarity**.

- The [DataApex Net-PAD Setup](#) dialog for setting the parameters that are set with respect to the type of connected signal.
- The *Method Setup - Acquisition* tab for setting the parameters related to the type of analysis.

4.1 DataApex Net-PAD Setup

The *DataApex Net-PAD Setup* enables you to set the basic parameters of the detectors.

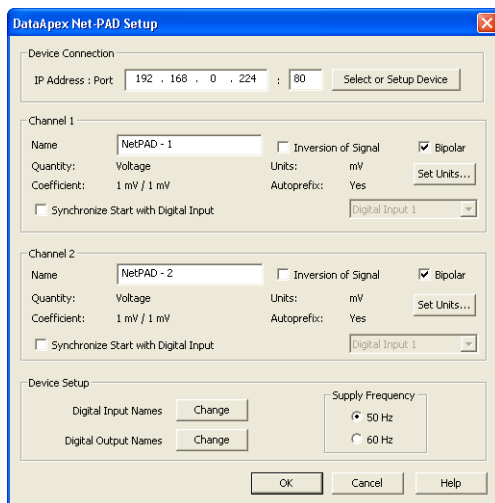

Fig. 14: DataApex Net-PAD Setup dialog

Device Connection

IP Address:Port

Displays the **IP Address** and **Port** number of the selected **Net-PAD**.

It can be changed using the *Select or Setup Device* button.

Select or Setup Device

Invokes the [DataApex Net-PAD Select](#) dialog for selecting the device and its in-depth configuration.

Channel 1 (2)

Sets the description of the respective channel (e.g. name of the detector).

Name

This field will be used to describe the signal in the *Chromatogram* window.

Inversion of Signal

Inverts the polarity of the signal from the detector.

Note: This function can be used for easy correction of improperly connected wires.

Bipolar

Positive and negative voltages will be measured.

Set Units...

Invokes the *Detector Units* dialog that can be used for converting the voltage measured by **Net-PAD** to the units of the detector. Such units will then be shown throughout **Clarity** instead of default mV. Setting is specific for each **Net-PAD** channel (signal).

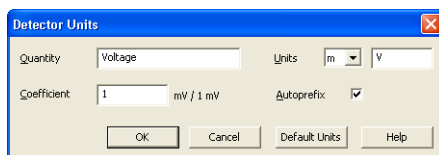

Fig. 15: *Detector Units*

- **Quantity** – Field for entering a name of the y-axis in the graph of the measured signal.
- **Units** – Field for entering the unit symbol, along with the prefix.
- **Coefficient** – Allows to enter the coefficient between the selected units and mV (default).
- **Autoprefix** – Allows to enter the unit prefix. In graphs, units will be scaled automatically, while in the tables, units with the prefix entered will be used.

Synchronize Start with Digital Input

Maps the **Net-PAD** Converter channel to selected *External Start Digital Input*. It enables faster and more accurate synchronization of channels with the start signal. Especially for short analyses the necessary time lags at the start of the acquisition are significant. When measuring multi-detector chromatograms it will minimize the time shift between detector signals and thus improve the detection of peaks.

Caution: Turn this function **ON** only in case one of the digital inputs of the configured **Net-PAD** is also set in the *Ext. Start Dig. Input* option in the [System Configuration](#) dialog.

Device Setup

This section allows to modify the naming of digital inputs and outputs and change the **Mains Supply Frequency Suppression** settings.

Digital Input Names

Allows to change the names of digital outputs.

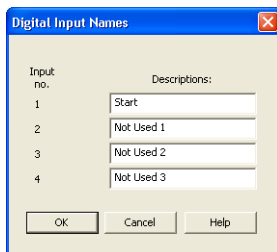

Fig. 16: Digital Input Names

Digital Output Names

Allows to change the names of digital outputs. These names will be used in the [Digital Outputs of Net-PAD](#) dialog.

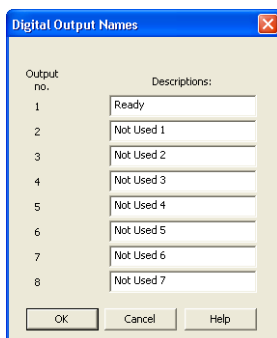

Fig. 17: Digital Output Names

Supply Frequency

Allows to change the **Mains Supply Frequency Suppression**. It is used for suppressing the interference on the specified frequency level. This setting influences the sampling frequency as well.

Note: In **most parts of Americas**, the **60 Hz** Mains frequency is usual, while the **rest of the world** tends to use **50 Hz** Mains frequency (pre-set as default). The **50 Hz** frequency is common in countries using **230V** power supply, while the **60 Hz** is connected to the **117V** power supply.

4.1.1 DataApex Net-PAD Select

The *DataApex Net-PAD Select (and Network Setup)* dialog is accessible by clicking on the *Select and Setup Device* button in the [DataApex Net-PAD Setup](#) dialog. It provides a list of all **Net-PAD** devices found in the local network. The selected **Net-PAD** can be configured in the lower part of the dialog.

Devices Available over network

The table lists all devices that have been found over the network using the **UDP** broadcasting protocol. The most important for the identification of the specific **Net-**

PAD is the production_preset_unique MAC Address of the device. All the other parameters can be user defined in the **Network Settings** section.

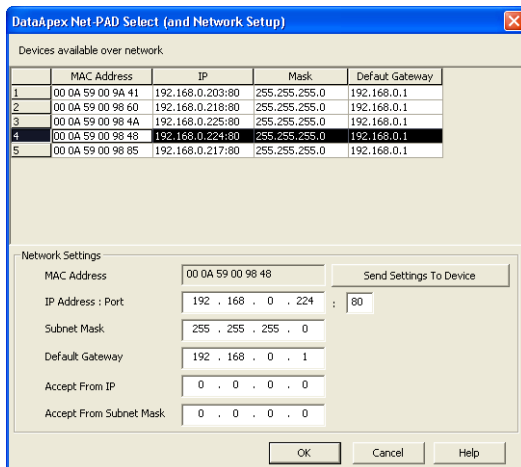

Fig. 18: DataApex Net-PAD Select (and Network Setup dialog)

Network Settings

MAC Address

MAC address is a unique network device address on the Ethernet and it is always factory preset.

Using this address, the devices can be distinguished in the UDP mode of the configuration program.

IP Address

Selects the **IP Address** of the **Net-PAD**. This address should conform to the IP range of the local network.

When using a **DHCP server**, a static IP must be reserved for **Net-PAD's** MAC address.

Note: **Net-PAD** does not support dynamic assigning of IP by the **DHCP server**.

Port

Sets the communication port of the **Net-PAD**. Allowed range: 1 - 19 999.

Subnet Mask Sets a bit mask used to tell how much of an IP address identifies the sub network the host is on and how much identifies the host.

Note: In most of the local LANs the preset Subnet Mask 255.255.255.0 can be used.

Default Gateway

For connecting out of local net - use the Gateway that is located in **Subnet Mask** allowed range of IP addresses.

Note: The **Default Gateway** is not necessary in local LAN, but IP addresses of both sides must be chosen from allowed **Subnet Mask**.

Accept From IP

Restricts communication only to the specified IP Address.

Note: Security can be greatly enhanced by setting a fixed address or a suitable restrictive mask (in **Accept From Subnet Mask** filed) that disallow communication with unauthorized parties.

Accept From Subnet Mask

This mask restricts addresses that may communicate with the **Net-PAD**.

Send Settings To Device

Sends the modified settings to the selected **Net-PAD**.

4.2 Method Setup

Parameters of the *Method Setup - Acquisition* and *Method Setup - Measurement* dialogs depend on the type of analysis (measuring conditions), so so they can be specific for various types of analyses. This is the reason for them to be a part of the method. The parameters can't be changed during the analysis.

Note: The parameters can't be changed during analysis.

4.2.1 Method Setup - Measurement

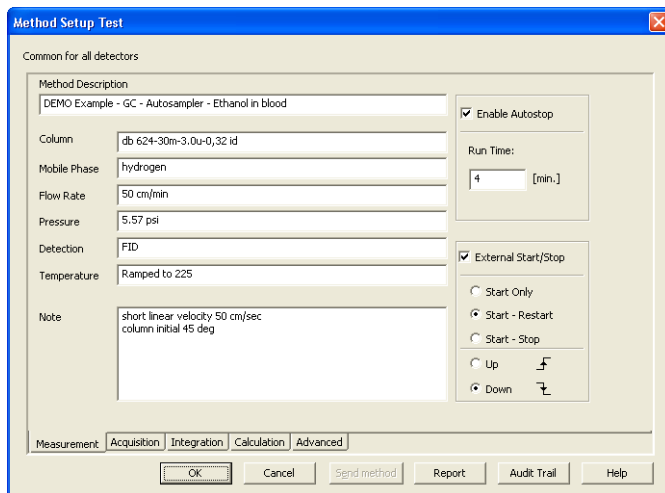

Fig. 19: Method Setup - Measurement

External Start/Stop

Enables control from an external signal.

Note: The Input used for an external Start from a chromatograph can be set in the *System Configuration* dialog, see **Fig. 8** on pg. 12. in the chapter "Clarity Configuration".

Start Only

The external signal only starts an analysis. Triggering the input will not influence the acquisition in progress.

Start - Restart

The external signal terminates the analysis in progress and at the same time starts a new one. The first signal starts the analysis; the second signal terminates it and at the same time starts a new one - the so-called continuous measurement.

Start - Stop

The external signal starts and stops an analysis. The first signal starts the analysis; the second signal stops it, etc.

Down

The station reacts to changes in voltage in the relevant controlling input from high (> 3 V) to low (< 0.7 V), or to contacts closed in the relay.

Up

The station reacts to changes in voltage in the relevant controlling input from low (< 0.7 V) to high (> 3 V), or to contacts opened in the relay.

4.2.2 Method Setup - Acquisition

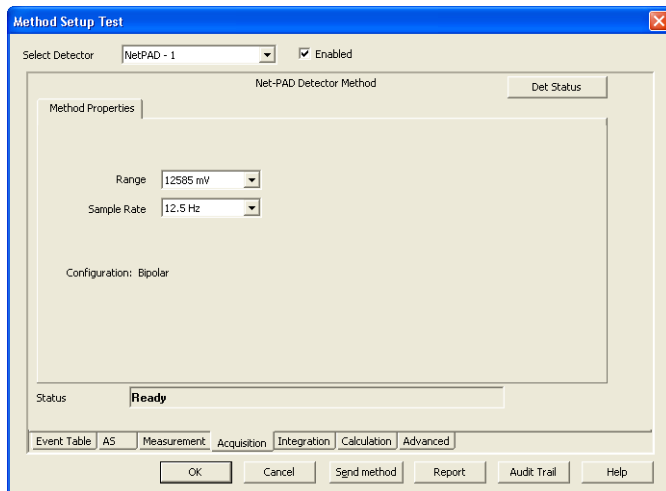

Fig. 20: Method Setup dialog - Acquisition tab

Select Detector

Selects the detector whose parameters are set. If there is only one detector (channel) configured on the **Clarity** Instrument, this control is not be displayed.

Range

Selects the input voltage range (in mV). The selected range corresponds to the maximum output voltage of the detector that the A/D converter can still process. In case the detector unit conversion is set in [Detector Units](#) dialog, the range will be shown in detector units according to the conversion, while the corresponding original range in mV will be shown next to the field.

Available ranges for **Net-PAD** converter are 156, 1 250 and 12 585 mV.

Sample Rate

Depending on *Supply Frequency* filter selected in [DataApex Net-PAD Setup](#) dialog. The available sampling rates are 6.25, 12.5, 25, 50 and 100 samples per second for 50 Hz supply frequency filter or 7.5, 15, 30, 60 and 120 samples per second for 60 Hz supply frequency filter.

Note: In most parts of the Americas, the 60 Hz Mains frequency is usual, while the rest of the world tends to use 50 Hz Mains frequency (pre-set as default). The 50 Hz frequency is common in countries using 230 V power supply, while the 60 Hz is connected to the 117 V power supply.

Higher sampling rate allows for the measurement of narrower peaks, but it also means a larger amount of data which affects the size of the resulting chromatogram and the speed of its processing.

Sample rate sufficient for successful peak detection is about 20 samples per narrowest peak.

A higher sampling rate also increases the amount of noise.

Note: *Range* and *Sampling Rate* are set individually for each detector.

Det Status

Invokes the *Hardware Configuration* dialog for the **Net-PAD** device.

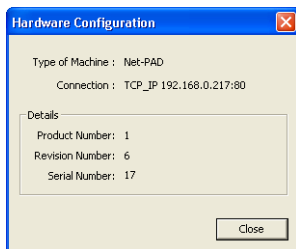

Fig. 21: Hardware Configuration dialog

In this dialog, type of connection, the revision number and the serial number of the **Net-PAD** device is listed.

4.3 Digital inputs and outputs

The **Net-PAD** converter is equipped with eight **digital TTL outputs**, which are also designed as relay contacts. It also has four **digital inputs** IN1 to IN4 equipped with optocouplers.

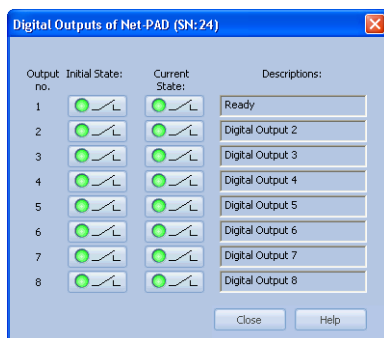

Fig. 22: Digital outputs of Net-PAD

These outputs can be controlled from the following places in **Clarity**:

- Standard assignment of external *Ext. Start Dig. Input* and *Ready Dig. Output* can be changed in the [System Configuration](#) dialog - ⑧ in the **Fig. 8** on pg. 12.

Note: The assigned input and output is then automatically used in the **ACTIVE** sequence for synchronization with the autosampler.

- *Digital outputs of Net-PAD* dialog.
- [Device Monitor](#) dialog.
- In the *Method Setup - Event Table* dialog.

4.4 Device Monitor

The *Device Monitor* window can be invoked by the *Monitor - Device Monitor* command from the *Instrument* window or using the **Device Monitor**  icon. It displays the states of digital inputs and enables the user to monitor and change the states of digital outputs.

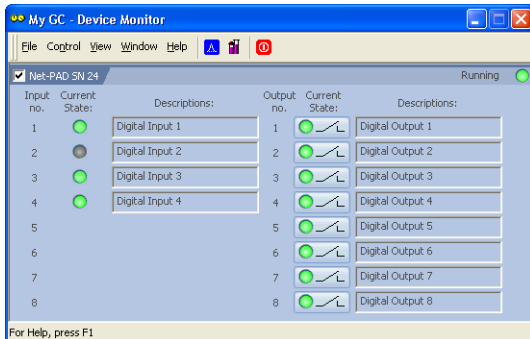

Fig. 23: Device Monitor - Net-PAD

Input no.

Lists the numbers of individual inputs.

Current State

Indicates the current status of the particular input. Green light corresponds to logical one (*HIGH*), light switched off (gray icon) to logical zero (*LOW*).

Descriptions

Shows the description indicating the meaning of individual input. The names of all digital inputs can be set in the [DataApex Net-PAD Setup](#) dialog.

Output no.

Lists the serial numbers of individual outputs.

Current State

Indicates the current status of the particular output which also works as relays. Green light corresponds to logical one (*HIGH*), light switched off (gray icon) to logical zero (*LOW*). The state of any output can be changed by clicking on the *Current State* button of the particular output.

Descriptions

Shows the description indicating the meaning of individual output. The names of all digital outputs can be set in the [DataApex Net-PAD Setup](#) dialog.

5 Troubleshooting

If you will not find your answers here, use the www.dataapex.com website where the Support menu will navigate you to frequently asked questions (FAQ), **Clarity** forum or contact to **DataApex** helpdesk.

5.1 Locate your problem

When troubles occur, the fastest way to find a solution for it is to search for it in the following index via the **Dialog** (window), in which the problem occurred, **Error Messages** that appear or according to utilized **Hardware**. The name of the window/dialog is visible in its header.

Note: Names of individual **Clarity Instruments** appear in the header instead of the common term "Instrument".

Tab. 2: List of windows and dialogs

Dialog	Messages
Clarity	pg. 30.
Data Acquisition	pg. 32.
Instrument	pg. 30.
Method Setup	pg. 30.
Sequence	pg. 30.
Single Analysis	pg. 30.
System Configuration	pg. 29., pg. 30., pg. 32.

Tab. 3: List of Error Messages

Error Messages	
Cannot establish communication with Net-PAD detector X	pg. 29.
DataApex Net-PAD(SN XX) Device not found	pg. 29.
Disabled (in the status line)	pg. 30.
Simulated (in Data Acquisition)	pg. 32.

Note: To find solutions for error messages not listed above, check the **Clarity Getting Started** Guide or visit our web pages www.dataapex.com.

5.2 Problems with Net-PAD

Most problems with **Net-PAD** driver are generally indicated by following symptoms:

- **Net-PAD** cannot be added to the *Setup Control Modules* in the *System Configuration* dialog.
- **Clarity** will issue an error message "Cannot establish communication with DataApex Net-PAD" when opening the *Instrument* window.
- Double-clicking on the device will not invoke the [DataApex Net-PAD Setup](#) dialog.
- **Clarity** will issue an error message "DataApex Net-PAD (SN:XX) Device not found" when starting **Clarity**.
- The *Data Acquisition* icon in the *Instrument* window is not active (this problem may also have another cause). For more details see the chapter **Data Acquisition - non-functional** on pg. 30.
- Digital Outputs of Net-PAD are switched with a delay.

■ Digital Outputs of Net-PAD are switched with a delay.

Description: Switching off the Net-PAD's Digital Outputs programmed at the same time is really delayed by 1 s due to communication over the network. This may sometimes be a problem for the BCD Input of the controlled device (instrument).

■ Net-PAD (SN Error) Cannot send sockets. Net-PAD is not communicating.

Description: This may be due to a faulty cable or that when using a direct connection the PC does not have a static IP address set up.

■ NETPAD malfunction.

Description: This message appears if the data do not arrive within 7.5 seconds.

■ There is a problem with detection of the available devices on network using the Select and Setup Device button. Net-PAD is not detected.

Description: This is a problem related to the operating system. Pressing the button *Select and Setup Device* in *Net-PAD Setup dialog* causes that UDP requests are sent to populate the device list. However, on Windows 10/11 this requests are sent to the default LAN adapter only (and it seems that Windows decides which one it is randomly) and in case the Net-Pad is connected to another one, it will not be detected.

Solution: Possible workaround is to disable the other LAN adapters temporarily to set up the Net-Pad IP address and other network settings. Once the IP address is assigned, the Net-PAD should work correctly. If not, check the firewall.

5.3 Data Acquisition - non-functional

Gray  icon with the heading "Disabled" and non-functional *Monitor - Data Acquisition* command.

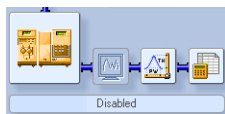

Fig. 24: Data Acquisition disabled

Other manifestations of this error are also: [Method Setup - Acquisition](#) tab missing, *Method - Acquisition* command non-functional, *Run*, *Stop*, *Abort* commands non-functional in the windows *Single Analysis* and *Sequence*. Possible causes are:

Description: a) You are using **Clarity Offline** or a **Clarity DEMO** version, which does not enable the measurement of chromatograms.



Fig. 25: Clarity Offline and Clarity DEMO

Check whether there is a blue line with the title **OFFLINE** displayed in the main *Clarity* window under the symbols of the Instruments, or the title **Demo** in the *Clarity* window header.

Solution: In case of **Clarity DEMO**, use the **Windows Start** menu to locate the **Clarity DEMO** group in the *All Programs* section and select the *Remove Clarity* item there.

Then, use the correct **Clarity** installation DVD to install the full version.

In case of the **Clarity Offline** station, remove the HW key with the **Offline** license and insert key with the **Clarity** full licence.

Description: b) Detector is not allocated to the **Clarity** Instrument:

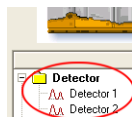

Fig. 26: Detector not allocated to the Instrument

Solution: Open the *System Configuration* dialog from the *Clarity* window using the *System - Configuration...* command and check the tab of the corresponding Instrument - **Instrument X**. If it has no allocated detectors, add them.

In the left-hand list *Setup Control Modules* select the correct detector connected to the **Net-PAD** you are using and drag it to the corresponding instrument on the right.

If your **Net-PAD** is not in the left-hand list *Setup Control Modules*, add it using the *Add* button and repeat the previous step.

Note: More information on the *System Configuration* dialog can be found in the chapter "**Clarity Configuration**" on pg. 12.

Description: c) You have a licence purchased for data collection from a smaller number of Instruments:

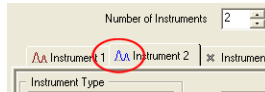

Fig. 27: Small number of Instruments purchased

Open the *System Configuration* dialog from the *Clarity* window using the *System - Configuration...* command and check the tab of the corresponding Instrument - **Instrument X**. Blue symbol of the curve in the tab header indicates that Instrument is not usable for measuring.

Solution: Check your serial number S/N for example using the command *Help - About...* from the main *Clarity* window.

5.4 Data Acquisition - Simulated

The title "Simulated" is displayed in the *Data Acquisition* window.

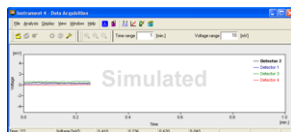

Fig. 28: Data Acquisition Simulated

Description: The corresponding Instrument only displays the simulated curve (from the file CHANNX.DTA file) in the *Data Acquisition* window, or in other words has allocated a **DEMO detector** on itself.

Open the *System Configuration* dialog from the *Clarity* window using the *System - Configuration...* command and check the tab of the corresponding Instrument - **Instrument X**. If it only has the detector signals from the **DataApex DEMO** detector, it is necessary to configure it once more:

Solution: Open the *System Configuration* dialog from the *Clarity* window using the *System - Configuration...* command and check the tab of the corresponding Instrument - **Instrument X**. If it only has the detector signals from the **DataApex DEMO** detector, it is necessary to reconfigure it. You can find more information how to add a detector in the chapter "**Clarity Configuration**" on pg. 12..

If you have a proper detector configured on your Instrument, the **Clarity** may be in the *DEMO MODE* due to improperly entered user code. This is indicated by the *DEMO - TRIAL EXPIRED* red label in the main window. If so, check the user code using the *Help - User Code* menu in the **Clarity** main window.

6 Tables and specifications

Tab. 4: Specifications:

Parameter	Value
Converter type	24 bit integrating, sigma – delta
Analog inputs	Symmetrical, mutually isolated
Number of A/D channels	2
Input range	Unipolar and bipolar, each channel independently 156, 1 250 or 12 585 mV
Input impedance	1 MΩ
Sample rate	6.25, 12.5, 25, 50, 100 samples per second for 50 Hz mains frequency filter 7.5, 15, 30, 60, 120 samples per second for 60 Hz mains frequency filter
Non-linearity	< 0.0007 %
Temperature dependence	< 10 ppm/°C
Digital inputs	4 TTL (5 V), the first two can be controlled using the built-in opto-electronic unit (2-5 mA current)
Digital outputs	8 TTL (5V, maximum current load 30 mA), the first four control relays (100 V/0.5 A)
Auxiliary ports	2x RS232 serial communication
Dimensions	133 x 105 x 21 mm (w x h x d)
External power supply	6 V/250 mA

Tab. 5: Network communication:

Parameter	Value
Protocol	TCP/IP
IP Address	configurable
Ethernet (LAN)	10Mb/sec
Connector	RJ-45 (twisted pair)

6.1 Description of the INT7 connector (Male)

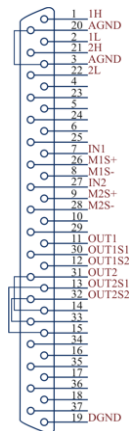

Fig. 29: Connector pins

Tab. 6: Description of the connector pins:

Parameter	Value
1H	+ Input of the 1st channel
1L	- Input of the 1st channel
AGND	Ground of the analog channels
IN1	Digital input (of the 1st channel). Used as an External Start (marker) of the 1st channel
OUT1	1st Digital output Digital outputs are controlled by <i>Event Table</i> , <i>Active Sequence</i> and <i>Digital Output dialog</i> .
DGND	Ground of the digital inputs and outputs.
M1S+	+ pin of the 1st Digital input. Level is <i>LOW</i> when current flows between M1S+ and M1S-.
M1S-	- pin of the 1st Digital input.
OUT1S1 OUT1S2	Digital outputs - 1st relay contact. Contact is closed when output is at a <i>LOW</i> level.

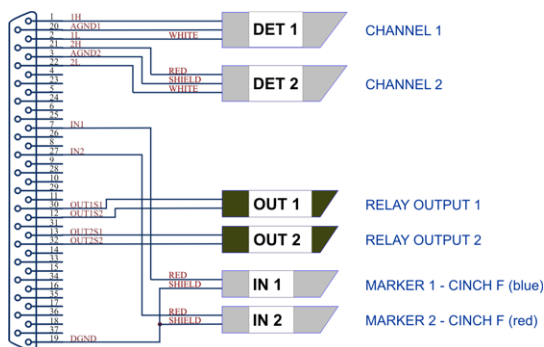

Fig. 30: Standard INT7 cable for two detectors

6.2 Parameters of digital inputs and outputs

Digital outputs

The card contains eight digital TTL outputs (OUT1- OUT8) with a maximum permissible current of 20 mA at both levels.

The first four outputs are also designed as relay contacts (OUT1S1/OUT1S2-OUT4S1/OUT4S2).

The maximum permissible current is 100 mA , the maximum-switched voltage is 100 V and the contact resistance is $150\text{ m}\Omega$. The relay is onstate (closed) when there is a *LOW* level of a relevant digital output.

Digital inputs

The card contains 4 digital inputs IN1 to IN4.

The first two inputs are also equipped with an optoelectronic isolator. The excitation current is 5 mA and corresponds to input level *LOW*.

The LED of the isolator is directly connected to the connector.

Caution: A resistor must be inserted (e.g. in the connector) to restrict the diode current to 10 mA max.

To suppress contact bouncing the digital inputs are equipped with monostable toggles that prolong any change affecting the input to at least 200 ms (to ensure that the station is able to detect it).

A pulse of at least 1 ms duration is necessary in order to excite the toggles.

6.3 Disposal and Recycling



Electrical and electronic equipment must **not be** disposed of as unsorted municipal waste.

It should be collected separately to ensure proper treatment and recycling. Please return used equipment to designated collection points.